



XLT[®]

Simple. Smart.

3255F GAS

**32" Wide Conveyor
55" Long Cooking Chamber**



STANDARD FEATURES

- Available as a double or triple stacked oven
- Stainless Steel construction throughout
- Easy to clean removable front panel
- Tough durable digital controls
- Instant reversible conveyor direction
- Front access loading window
- Removable crumb trays

OPTIONAL FEATURES

- Split belts, giving 2 belts with individually adjustable speed settings
- Conveyor shelf extensions
- Fire suppression pre-piping
- Sandwich door handle options
- Extended front panels (powder coat color options)
- Lower oven base shelf
- Stainless steel door lifting handles

**304 STAINLESS STEEL | 7 YEAR PARTS AND LABOR WARRANTY | 24 HR CUSTOMER SERVICE
5 YEAR INTERNATIONAL PARTS AND LABOR WARRANTY**

WWW.XLTOVENS.COM



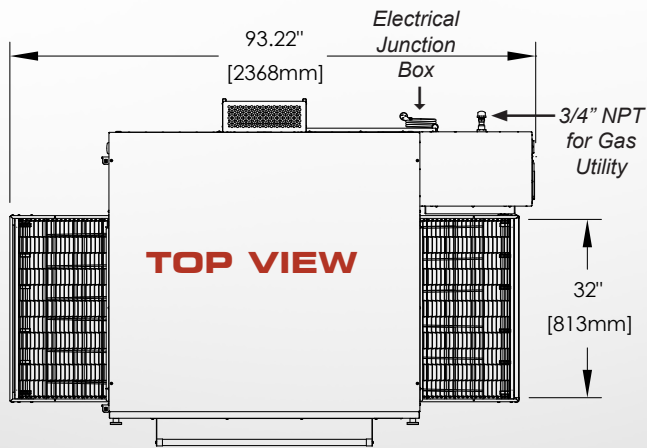

Simple. Smart.

3255F
GAS

FRONT VIEWS:

SIDE VIEWS:

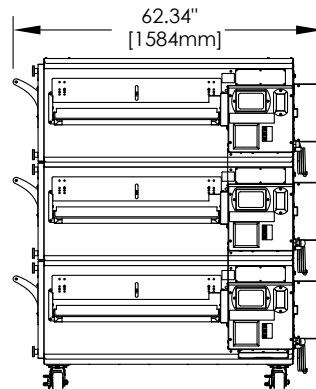
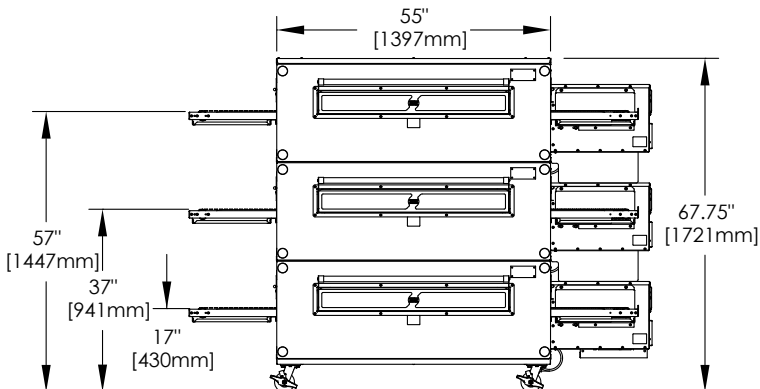
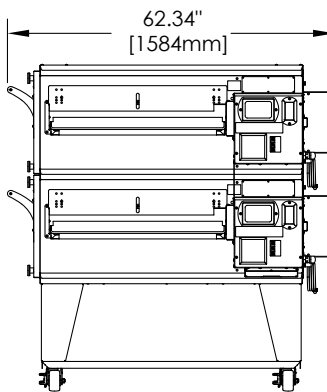
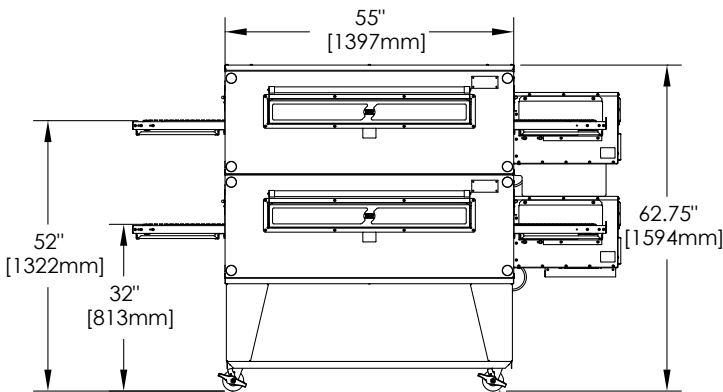
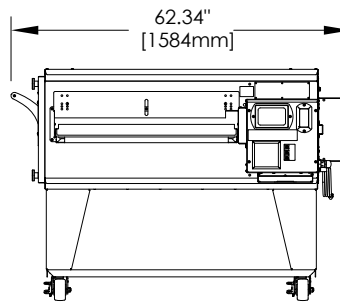
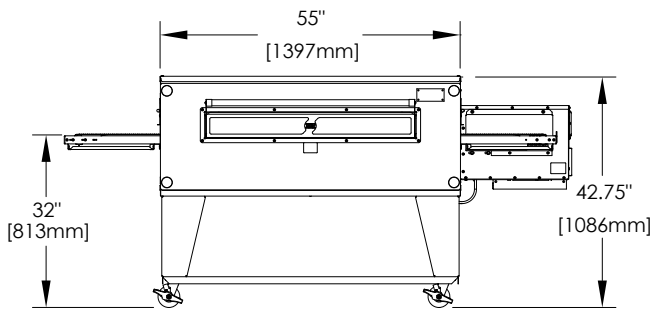

HEATING VALUES
 BTU/HR - 115,000
 KW/HR - 33.70
 MJ/HR - 121.32

ELECTRICAL REQ.
 120 VAC 4.8 Amps
 50/60 Hertz
 220/240v options

INLET PRESSURE RANGE NATURAL GAS
 W/C 6-14
 MBAR 15-35
 kPa 1.5-3.5

INLET PRESSURE RANGE LP GAS
 W/C 11.5-14
 MBAR 27.5-35.0
 kPa 2.75-3.50

MANIFOLD PRESSURE RANGE NATURAL GAS
 W/C 3.5
 MBAR 8.75
 kPa 0.875

MANIFOLD PRESSURE RANGE LP GAS
 W/C 10
 MBAR 25
 kPa 2.5

WEIGHT PER DECK
 884 lbs / 401 kg

V16 - 01

WWW.XLTOVENS.COM



N4279 Intertek Intertek 0359