



Technical Description



- Display case with switch function for quick switchover possibility between cold and hot operation – optimally matched to 24/7 operation
- Display case that can be used in a variety of ways for the presentation of various cold or hot snacks on multiple levels
- Optimal possibility to react to time-of-day based demand.
- Cooling mode: Air-curtain cooled refrigerated display case for assisted service for the best-possible energy efficiency in on-going operation
- Heating mode: Supporting heat for assurance of the optimum surface and core temperature of the product
- Intermediate shelf and display area made of black glass
- Panoramic and side windows made of tempered safety glass
- Operator side with sliding doors made of insulating glass
- Long-lasting, heat-resistant LED lighting per level
- Pressure-foamed inner well, welded tight
- Coated, circulating air fin coil evaporator with fan, low-voltage, can be folded up and rinsed
- Control unit with temperature display, speed control of the fan, as well as on/off switch
- Fully automatic condensate evaporation; condensate drain HD 30
- Easiest cleaning and perfect hygiene



TECHNICAL DATA

Subject to change without notice



	WK 80-70-E	WK 112-70-E	WK 145-70-E
Presentation levels	2	2	2
Presentation area, cold	0,65 m ²	0,96 m ²	1,27 m ²
Refrigerant	R134a	R134a	R134a
Outside dimensions (in mm)			
Width x depth x height*)	800 x 695 x 700	1125 x 695 x 700	1450 x 695 x 700
 Installation opening (in mm)			
Width x depth	760 x 670	1085 x 670	1410 x 670
Opening clearance dimension A	295	455	620
 Performance data, cooling mode			
Refrigeration capacity evap. @ -10 °C	400 W	480 W	600 W
Power input, self-contained	489 W	510 W	575 W
Power input, remote-refrigeration	89 W	110 W	135 W
 Performance data, heating mode			
Power input hot	0,8 kW	1,09 kW	1,35 kW
Voltage	230 V 50 Hz		

*) Height of glass cover without built-in part

All product illustrations are only symbolic photos. They may differ from the actual units. The specific product properties can be found in the individual product descriptions.

Built-in combo display case Switch height 700 mm



The Highlights



Switch unit: Two in One. Heating and refrigeration system combined in one unit. Easy to switch over, practical to use and perfect space savings – optimal for reaction to time-of-day based demand.



Supporting heat: Radiant heat from infrared heating. The heat that is guided from top to bottom provides an optimum effect for assurance of the optimum surface temperature and core temperature of your products.



LED lighting: Brilliant display case lighting for an attractive product presentation. Long-lasting, heat-resistant LED lighting with natural colour reproduction on all presentation levels ensures good and energy-saving illumination of your products.



Easy Clean: Optimum cleaning and best-possible hygiene thanks to rounded corners, lift-up intermediate shelves, glass cover that can be raised and lift-up black glass and evaporator.

TEMPERATURE RANGE



AIR, COLD
+5 °C

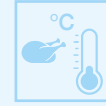

PRODUCT, HOT
> +65 °C

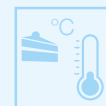

PRODUCT, COLD
M2: -1 °C to +7 °C



ROOM
+25 °C and 60% rh

OPTIONS		ITEM NO.	PRICE
Price tag holders	per linear metre	303 899	57,00
Sliding doors in a mirrored design	Surcharge		on request

04 Switchable Display Cases

GLASS ENCLOSURE ROUND

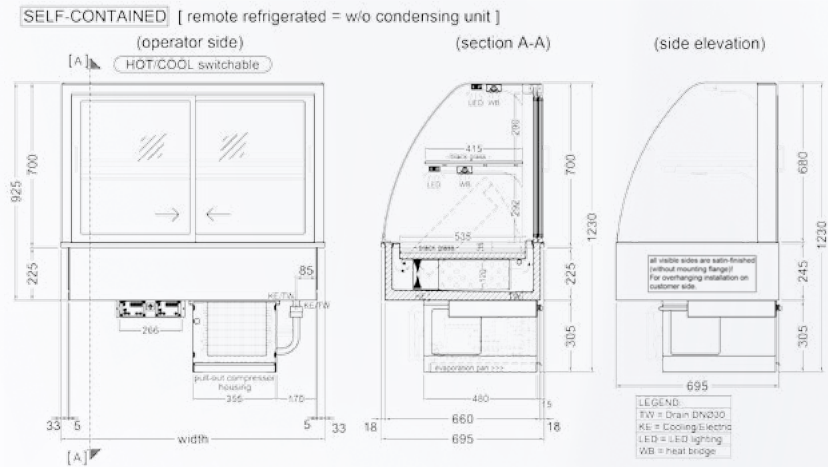

GLASS ENCLOSURE SQUARED

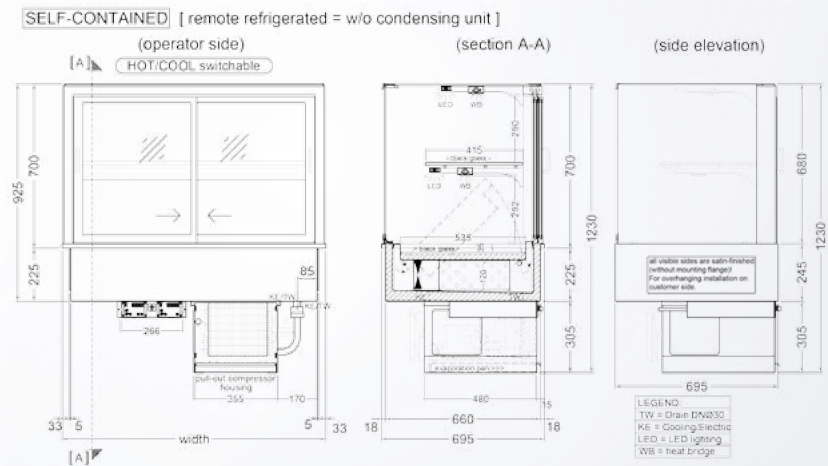

GLASS ENCLOSURE INCLINED

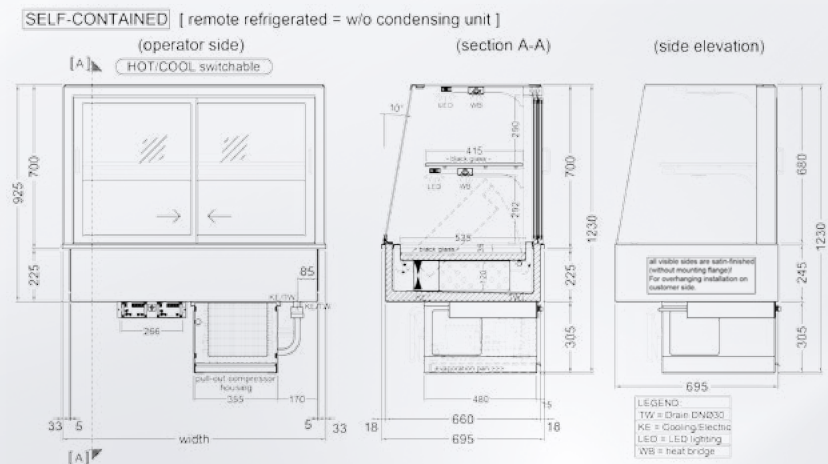

All product illustrations are only symbolic photos. They may differ from the actual units. The specific product properties can be found in the individual product descriptions.