

FLANTASTIC



Highlights



SOFT-OPEN



ENERGY-EFFICIENT



EASY-CLEAN



MIRROR-EFFECT



LED LIGHTING

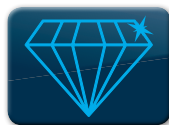

HIGH-QUALITY MATERIALS

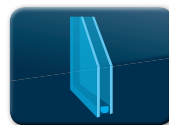

INSULATING GLASS

TECHNICAL DESCRIPTION

→ Cake display case with increased air humidity of 85%!

→ NEW operator side: 3 flaps with pull-out glass shelf for easy product removal.

→ Customer side: panoramic window made of insulating glass with high transparency.

→ LED lighting, baker colours on all display levels for natural colour reproduction and attractive food presentation.

SELF-CONTAINED

Model	Type	Item No.	Price
inclined	FLANTASTIC 92-E	332 600	11.976,-
	FLANTASTIC 132-E	332 601	13.932,-
squared	FLANTASTIC 92-E	332 602	11.976,-
	FLANTASTIC 132-E	332 603	13.932,-

REMOTE REFRIGERATION

Model	Type	Item No.	Price
inclined	FLANTASTIC 92-Z	332 605	10.344,-
	FLANTASTIC 132-Z	332 606	12.081,-
squared	FLANTASTIC 92-Z	332 607	10.344,-
	FLANTASTIC 132-Z	332 608	12.081,-

TEMPERATURE RANGE



Air
+2 °C



Product
M1: -1 °C to
+5 °C



Surroundings
+25 °C and max.
60% RH



ACCESSORIES AND OPTIONS

Moveable on casters (height 105 mm) instead of height-adjustable feet

529 120

469,-

self-contained or remote; height 1410 mm

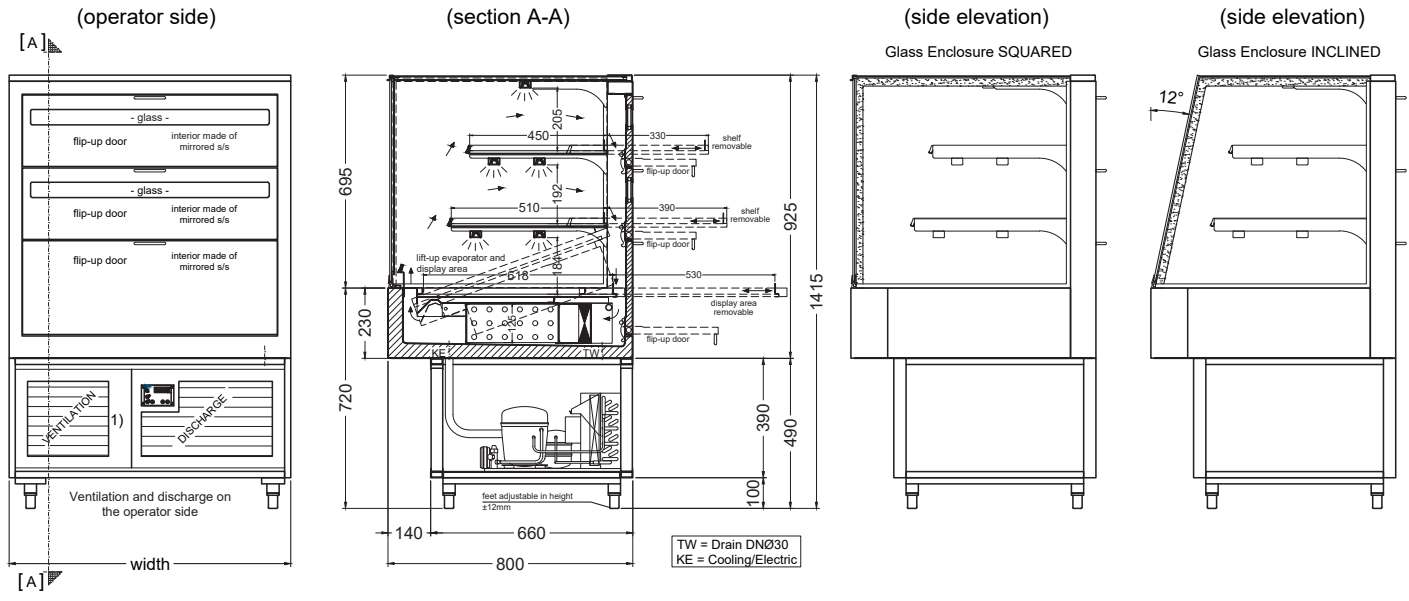

DISPLAYS FOR CAKES AND PASTRIES

TECHNICAL DATA

Dimensions in mm	FLANTASTIC 92	FLANTASTIC 132
SELF-CONTAINED		
Outside dimension width x depth x height	920 x 800 x 1415	1325 x 800 x 1415
Presentation area in m ²	1,25	1,89
Air temperature range	+2 °C	
Refrigeration capacity evap. @ - 6 °C	605 W	661 W
Refrigerant	R134a	
Power input	400 W	601 W
Energy consumption / 24h	4,61 kWh	6,92 kWh
Voltage	230 V 50 Hz	
REMOTE REFRIGERATION		
Outside dimension width x depth x height	920 x 800 x 1415	1325 x 800 x 1415
Presentation area in m ²	1,25	1,89
Air temperature range	+2 °C	
Refrigeration capacity evap. @ - 6 °C	605 W	661 W
Refrigerant	R134a	
Power input	85 W	131 W
Voltage	230 V 50 Hz	