



MIX'N MACHINE®

Create Popular Frozen Treats

The Mix'n Machine easily mixes candy, cookies, or fruit with ice cream or frozen yogurt for exciting and high profiting mix-in treats and shakes. Engineered for outstanding durability and convenience, the Mix'n Machine is a favorite in the frozen treat market.

Smart Product Design

- Brushless induction motor for durable and consistent speed regardless of thickness
- Protective, removable splash guard for easy clean-up
- Variety of efficient agitator options allows you to mix both hard and soft ice cream and yogurt



Mix-in treats



Product Specifications

Mix'n Machine® Item No. 575

Motor: 3440 RPM bare motor speed
 Electrical: 220 - 240 V, 50/60 Hz, 285 - 325 W
 Pack: Includes Mix'n Machine with removable/reusable agitator, includes 10 removable agitators and foot pedal.

Net Weight:

On-Counter: 11,4 kg (12,7 kg with box)
 Wall-Mount: 11,4 kg (12,7 kg with box)

Dimensions:

On-Counter: 60,9 x 25,4 x 20,9 cm (H x W x D)
 Wall-Mount: 51,0 x 18,5 x 22,0 cm (H x W x D)

Warranty: Please contact your authorized Vitamix distributor for warranty information.

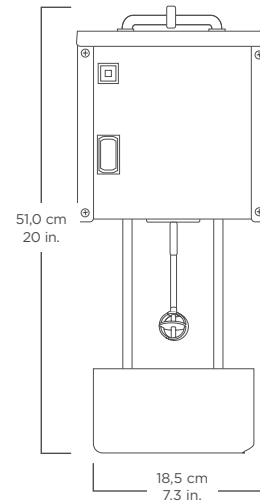
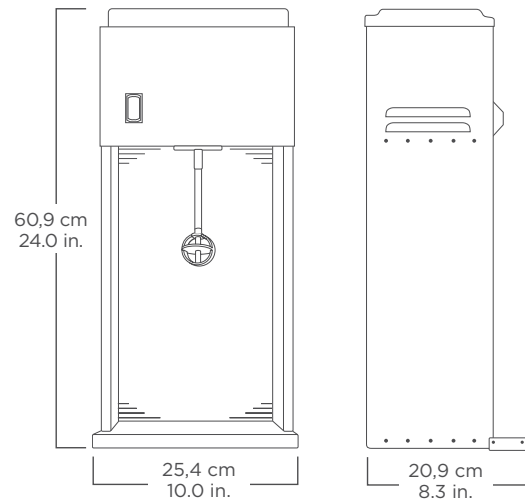

Also Available

Mix'n Machine
 Item No. 25009: 100 V, 50/60 Hz, 100 2,6 A

For more information, please contact an authorized Vitamix distributor, or Vitamix international customer service.

