



THE QUIET ONE™

Up to 4 Times Quieter Than the Competition

Innovative vibration dampening technology creates Vitamix quality drinks in a more enjoyable customer atmosphere.

Magnetically Secured Floating Sound Enclosure

Dramatically easier to clean and disassemble. No screws to damage the enclosure. No parts to lose.

Ultimate Blending Flexibility and Optimization

Variable speed control and automatic shut-off provide flexibility in creating endless recipes. The 6 program buttons with 34 optimized programs in memory provide operators with easy, consistent drinks every time. Custom blending programs can easily be created for signature drinks.

Improved Speed of Service

The Advance® container design reduces blend and pour time for faster customer service.

Designed for High Performance and Durability

Air management and powerful ≈ 3 peak output HP motor reduces noise, improves reliability and reduces down time.



Creamy fruit smoothies

Product Specifications

The Quiet One™

On-Counter: Item No. 50031 / In-Counter: Item No. 51024

Motor: ≈3 peak output horsepower motor

Electrical: 220 - 240 V, 50/60 Hz, 1300 - 1500 W

Pack: Includes The Quiet One™ Blending Station® Advance® with 1,4 L high-impact, clear/stackable Advance® container complete with blade assembly and lid compact enclosure

Net Weight: 9,1 kg, (12,7 kg with box)

Dimensions:

On-Counter: 45,7 x 21,6 x 27,2 cm (H x W x D)
Height with lid open: 62,2 cm

In-Counter: 41,9 x 21,6 x 27,2 cm (H x W x D)
Height with lid open: 58,4 cm
Depth below counter: 3,0 cm

Warranty: Please contact your authorized Vitamix distributor for warranty information.

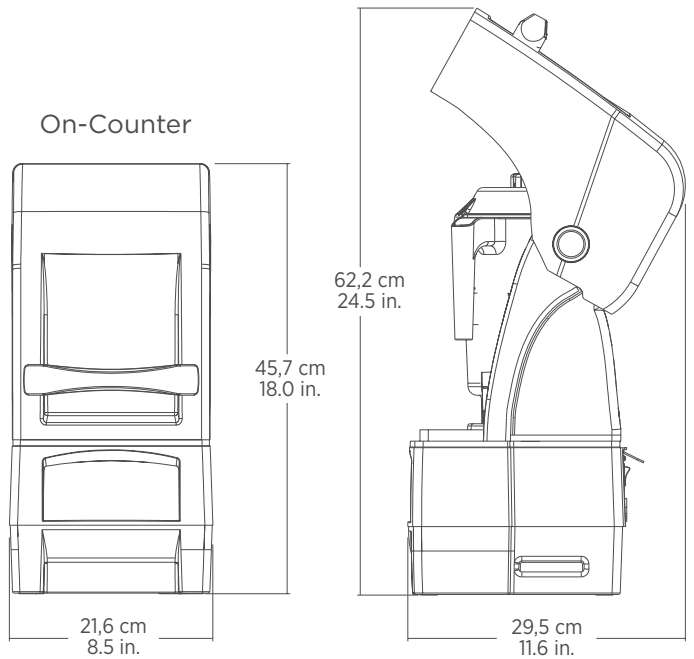

Also Available

The Quiet One On-Counter

Item No. 36209: 120 V (EMC), 50/60 Hz, 15 A

Item No. 52005: 100 V, 50/60 Hz, 1300 W

The Quiet One In-Counter

Item No. 36300: 120 V (EMC), 50/60 Hz, 15 A

Item No. 53005: 100 V, 50/60 Hz, 1300 W

Additional containers, complete with blade assembly and lid.

Item No. 15978: Advance container 1,4 L

For more information, please contact an authorized Vitamix distributor, or Vitamix international customer service.

