



VITAMIX XL® VARIABLE SPEED

Serve More With A Single Blend

Maximize your kitchen's possibilities with the largest capacity, countertop blender. Blend up to 24 (240 mL) servings at once! The XL is engineered to reduce prep-time, improve staff efficiency, and expand your menu capabilities.

Smart Product Design

- Powerful 4,2 peak output HP motor allows heavy blending from delicate tomatoes to dense meat
- Large 5,6 L container provides extra blending capacity for both hot and cold ingredients
- Low countertop profile and removable lid plug make it easy to add ingredients while blending
- Pulse function and variable speed control increase blending versatility



Blend hot and cold ingredients

Product Specifications

Vitamix XL® Variable Speed: Item No. 10185

Motor: ≈4,2 peak output horsepower motor
 Electrical: 220 - 240 V, 50 Hz, 7,5 A
 Pack: Includes Vitamix XL with accelerator tool and 2 containers (5,6 liters and 2,0 liters) complete with blade assembly and lid.

Net Weight: 22,7 kg
 Dimensions: 47,3 x 21,6 x 48,3 cm (H x W x D)

Warranty: Please contact your authorized Vitamix distributor for warranty information.

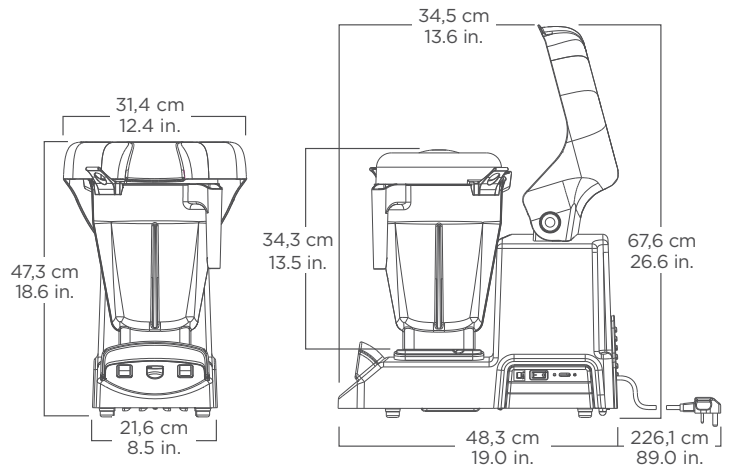

Included

2,0 L container

Accelerator tool

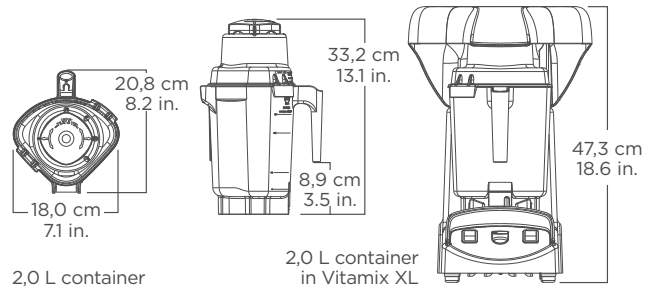

Also Available

Additional containers, complete with blade assembly and lid.
 Item No. 15899: Vitamix XL container 5,6 L
 Item No. 15894: Vitamix XL container 2,0 L

For more information, please contact an authorized Vitamix distributor, or Vitamix international customer service.