



ADVANCE® CONTAINER

Greater Efficiency and Speed of Service

The Advance container creates faster, smoother pouring and has a longer container and blade life.

Smart Product Design

- Unique shape and design improves blends and pourability, resulting in time and cost savings and an improved speed of service
- Built-in, dripless spout means less mess and waste
- Superior durability with double-sealed bearings, provides a longer blade life
- Shatter-proof polycarbonate container
- Operates with current machine programming or allows for new, more efficient programming



Unique shape and design

Product Specifications

Advance® Container

Item Number: 15981
 Pack: Includes 0.9 L high-impact, clear/stackable Advance container, complete with Advance blade assembly and lid.
 Net Weight: 1.0 kg (0.9 kg with box)
 Dimensions: 26.7 x 18.0 x 20.8 cm (H x W x D)

Advance Container

Item Number: 15978
 Pack: Includes 1.4 L high-impact, clear/stackable Advance container, complete with Advance blade assembly and lid.
 Net Weight: 1.0 kg (0.9 kg with box)
 Dimensions: 26.7 x 18.0 x 20.8 cm (H x W x D)

Warranty: Please contact your authorised Vitamix distributor for warranty information.

15981 and 15978

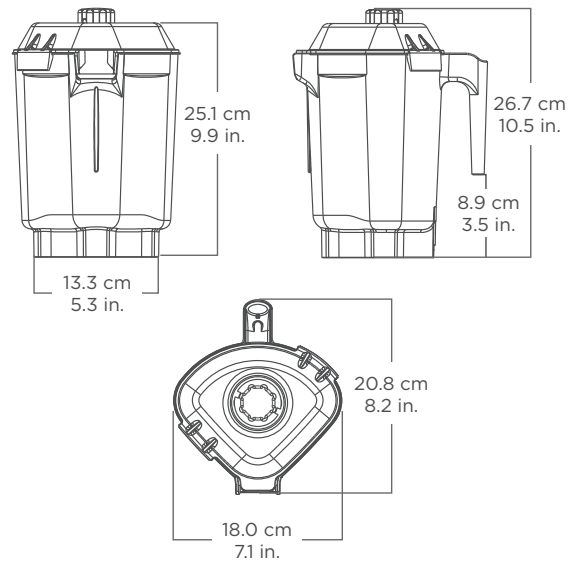

Where applicable:



Also Available

Item Number: 15092: Rubber splash lid with tethered lid plug. For Advance container only.



Compatible Machines

Advance Container

Item Number: 15981: Drink Machine Advance®
 BarBoss® Advance®
 T&G® 2 Blending Station®
 15978: Blending Station® Advance®