

Induction appliance with 4 multifunction hobs MS-I-40M, 4 × 7 kW

Item no. 120825



Standalone devices of cooking suite quality: Top quality «à la carte» range

A top quality cooker for small restaurants. Maximum flexibility in application. Ideal for «à la carte» cooking as well as for set menu dishes. Four induction hobs controlled independently, designed for everyday use.

Benefits that are spot on

- Energy saving increased by 50 to 85 % as compared to conventional cooking technology
- Minimum heat emission levels allow for an optimum kitchen working environment
- Extremely quick boiling times. Maximum heat output is achieved within just a few seconds.
- Freely adjustable, highly precise energy metering for perfectly cooked food
- Maximum power density per cm² at pan base
- Pan type detection (material, size, power consumption properties)
- 2-zone pot detection and temperature monitoring
- Automatic fan monitoring

Equipment

Multi-segment digital display
Extra-strong ceramic glass
Removable grease filter
Height-adjustable feet
Wall shroud optional

5th-generation technology

MENU SYSTEM
Induction technology



- MENU SYSTEM induction technology is the most up-to-date, highest performing and most advanced induction technology in the world.
- MENU SYSTEM leads the market, developing and producing all the components of this induction technology in-house.
- Its unique position in the field of cooking equipment construction enables the company to concentrate all its efforts on this forward-looking technology.
- No other company has more experience in the development and application of induction technology in professional kitchens.

MS-I-40M
Item no. 120825

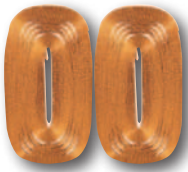

Top quality «à la carte» range

4 Multifunction induction hobs 7 kW each

The multifunction hob is ideal for cooking with two to four pans. Thanks to the capacity and high power density of the coil, it's a perfect choice for both production and finishing.

- For 4 saucepans measuring 16 cm or a cooking pot up to 38 cm
- Effective field \varnothing 340 x 360 mm
- 2-zone pot detection and temperature monitoring

Design

- Hob made from high-quality glass-ceramic material
- Complete housing made from solid stainless steel (Chromium nickel steel 1.4301)
- Removable, easy to clean grease filter
- Height-adjustable feet
- Continuously variable, electronic power control for highly precise energy metering
- One-handed operation using a rotary switch
- Control and power electronics resistant to power supply fluctuations

Technical data

Dimension	800 x 800 x 200 mm
Glass dimension	2 x 360 x 660 mm
Connected load	4 x 7 kW 3 x 400–440 VAC 50/60 Hz
Heat emission	latent 1960 W sensible 2240 W
Plug	CEE 32
Cable length	3 m
Weight	66 kg

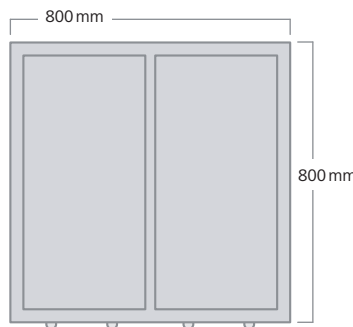

Safety instructions

The exhaust air must be allowed to escape unobstructed. The grease filters must be cleaned regularly.

The experience MENU SYSTEM has gained as the leader of the induction cooking suite market flows directly into the design and development of our standalone appliances. Accordingly, our standalone appliances provide the ideal response to the needs of professionals.



Quality guaranteed

Our manufacturer's warranty vouches for the quality of our products. Depending on country and region, service and warranties are looked after either by MENU SYSTEM directly or by our authorised partners.



Made in Switzerland

With MENU SYSTEM, induction technology, electrical technology and metal-worked components all come from a single source. The high degree of vertical integration guarantees full control based on quality and expertise. For MENU SYSTEM, «Made in Switzerland» isn't just a label – it's a philosophy and a living reality.