



## BLENDING STATION® ADVANCE®

### The Right Blend of Timing and Speed

The Blending Station Advance has been engineered for perfection including a noise-reducing cover for an improved customer experience.

### Smart Product Design

- Powerful  $\approx 3$  peak output HP motor for unmatched performance on the toughest blends in coffee, smoothie, and ice cream shops
- 93 speeds, variable speed control, and automatic shut-off provide the ultimate in blending flexibility for creating an endless number of recipes to expand your menu offering
- 34 optimised programmes engineered to provide consistent results quickly and easily
- Advance® container creates faster, smoother pouring and has a longer blade life resulting in time and cost savings along with improved customer experience



Creamy, blended coffee drinks

## Product Specifications

### Blending Station® Advance®

Item Number:	On-Counter: 50029 In-Counter: 51022
Motor:	≈3 peak output horsepower motor
Electrical:	220 – 240 V, 50/60 Hz, 1300 – 1550 W
Pack:	Includes Blending Station Advance with 1.4 L high-impact, clear/stackable Advance® container, complete with Advance blade assembly and lid, and removable compact cover.*
Net Weight:	8.4 kg (10.0 kg with box)
Dimensions:	
On-Counter:	49.2 x 23.5 x 26.7 cm (H x W x D) Height with lid open: 69.1 cm
In-Counter:	38.1 x 22.9 x 26.7 cm (H x W x D) Height with lid open: 57.2 cm Depth below counter: 14.4 cm

Warranty: Please contact your authorised Vitamix distributor for warranty information.

\*Standard 2.0 L container cannot be used with the compact cover.

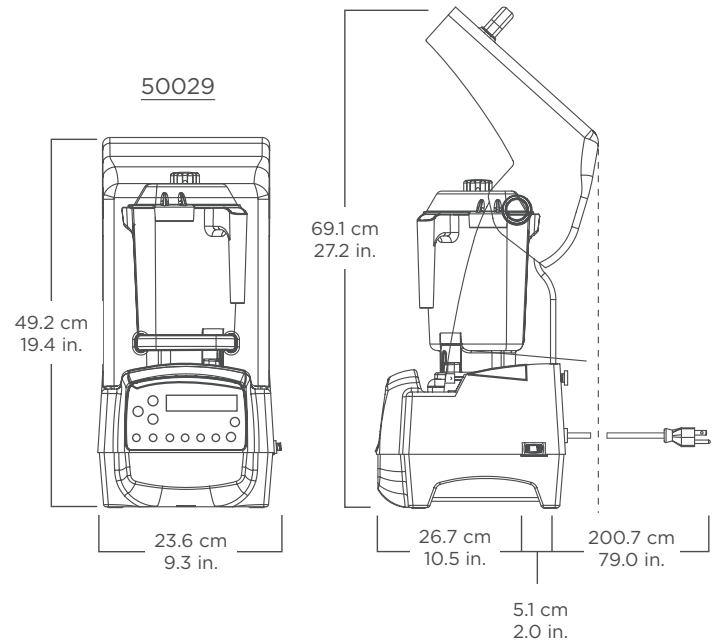

### Also Available

Additional containers, complete with blade assembly and lid.

Item Number:	15978:	Advance container 1.4 L
	15506:	standard container 1.4 L
	15640:	compact container 0.9 L

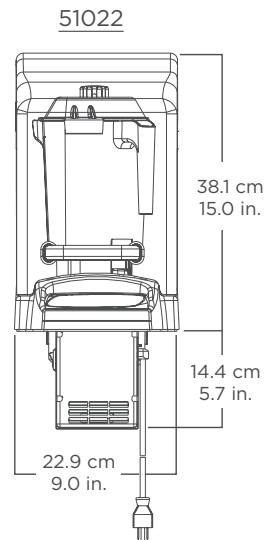

Where applicable:

