



T&G® 2 BLENDING STATION®

Powerful, Noise-Reduced Blending

The T&G 2 offers reduced sound and blending time. It quickly and easily creates smoothies, frappés, ice cream drinks and frozen cocktails.

Smart Product Design

- ≈2 peak output HP motor and sound-reducing cover for superior performance in coffee, smoothie, and ice cream shops
- 34 optimised programmes engineered to provide consistent results quickly and easily
- Advance® container creates faster, smoother pouring and has a longer blade life resulting in time and cost savings along with improved customer experience

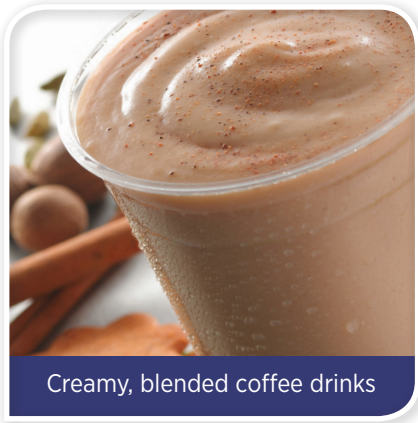

Creamy, blended coffee drinks

Product Specifications

T&G® 2 Blending Station®

Item Number:	On-Counter: 42009 In-Counter: 44004
Motor:	≈2 peak output horsepower motor
Electrical:	220 - 240 V, 50/60 Hz, 1075 - 1200 W
Pack:	Includes T&G 2 with 0.9 L high-impact, clear/stackable Advance® container, complete with Advance blade assembly and lid, and removable compact cover.*
Net Weight:	8.4 kg (9.5 kg with box)
Dimensions:	
On-Counter:	49.2 x 23.5 x 26.7 cm (H x W x D) Height with lid open: 69.1 cm
In-Counter:	38.1 x 22.9 x 26.7 cm (H x W x D) Height with lid open: 57.2 cm Depth below counter: 14.4 cm

Warranty: Please contact your authorised Vitamix distributor for warranty information.

* Standard 2.0 L container cannot be used with the compact cover.

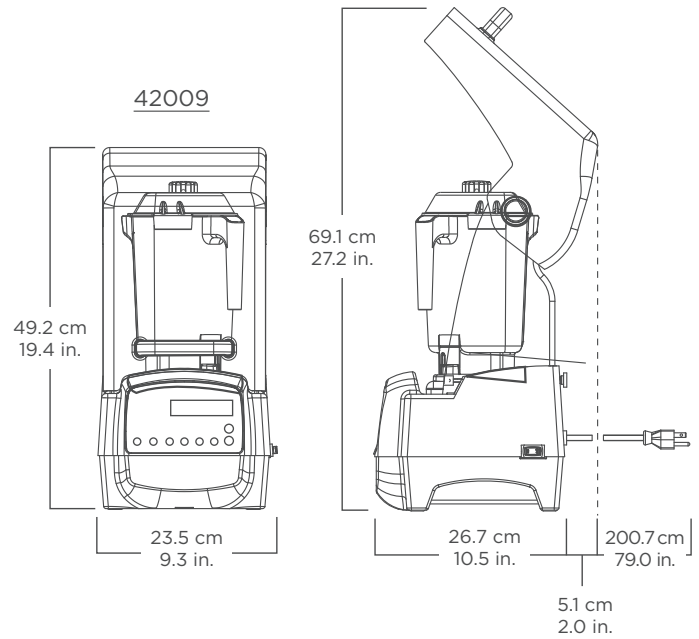

Also Available

Additional containers, complete with blade assembly and lid.

Item Number:	15981:	Advance container 0.9 L
	15506:	standard container 1.4 L
	15640:	compact container 0.9 L

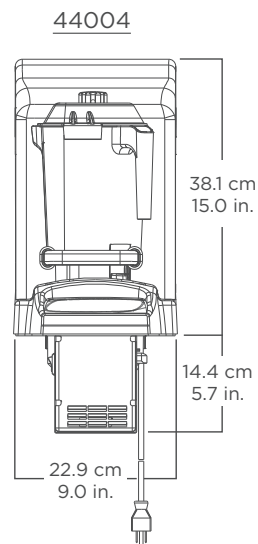

Where applicable:

