



VITA-PREP® 3

Unmatched Performance in Commercial Kitchens

Professional chefs and culinary schools around the world trust the Vita-Prep 3 for its exceptional power, versatility, and performance. From chopping delicate ingredients to blending tough purées, the Vita-Prep 3 is the only tool that's durable and capable of perfectly chopping, grinding, and blending it all.

Smart Product Design

- ≈3 peak output HP motor delivers unmatched performance when puréeing, grinding, chopping and more
- Variable speed and accelerator tool allows for control and easy processing of dense ingredients
- Advanced cooling fan for optimum reliability during peak hours of operation
- Patented, high-impact container is clear for seeing ingredients during operation



Perfectly chop ingredients

Product Specifications

Vita-Prep® 3

Item Number: 10089

Motor: ≈3 peak output horsepower motor
 Electrical: 220 - 240 V, 50 Hz, 1100 - 1200 W
 Pack: Includes Vita-Prep 3 with 2.0 L high-impact, clear container complete with blade assembly and lid, accelerator tool, and black base.
 Net Weight: 5.5 kg (6.8 kg with box)
 Dimensions: 51.4 x 20.3 x 22.9 cm (H x W x D)

Warranty: Please contact your authorised Vitamix distributor for warranty information.

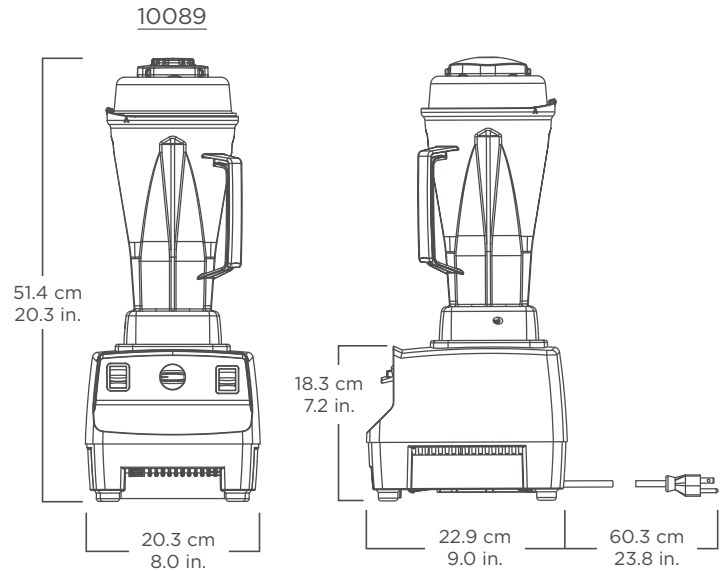

Also Available

Additional containers, complete with blade assembly and lid.

Item Number: 1195: container 2.0 L
 15504: standard container 1.4 L
 15652: compact container 0.9 L

Where applicable:

