



## MIX'N MACHINE® ADVANCE®

### Programmed Frozen Treat Mixer for Improved Results and Easier Operation

The Mix'n Machine Advance, the industry's leading frozen treat mixer, can incorporate sweets, biscuits, and other hard-to-mix ingredients into hard or soft serve ice cream or yoghurt. Easily expand your menu and make highly profitable frozen treats. Perfect for high-volume ice cream shops, smoothie shops and quick-service restaurants.

### Smart Product Design

- 6 optimised programmes let you customise your dessert treats and deliver consistency from location to location
- Easy-to-use pulse control quickly refreshes desserts
- Automatic shut-off and end-of-cycle indicator light improves ease-of-use and eliminates wasted ingredients
- Cup-activated lever with "smart" delay allows for simple one-handed operation
- Variety of efficient agitator options allows you to mix both hard and soft ice cream and yoghurt



Mix-in fruit



## Product Specifications

### Mix'n Machine® Advance®

25021

Item Number: 25021  
 Motor: 500 - 3000 RPM bare motor speed  
 Electrical: 220 - 240 V, 50/60 Hz, 150 - 180 W  
 Pack: Includes Mix'n Machine Advance with permanent soft ice cream agitator.  
 Net Weight: 8.7 kg (10.4 kg with box)  
 Dimensions: 61.0 x 25.4 x 21.0 cm (H x W x D)

Warranty: Please contact your authorised Vitamix distributor for warranty information.

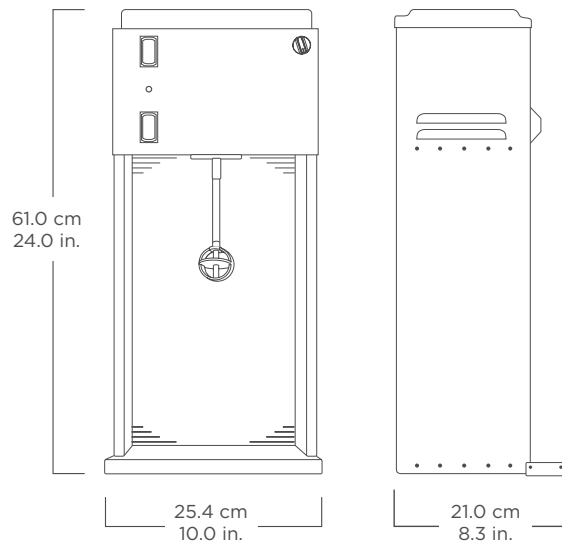

Where applicable:

